

Clip-in and hook-on ceilings



Concealed ceiling system.

Consists of two basic systems, hook-on and the clip-in, both can accommodate square tiles or rectangular panels. The hook-on system has been developed to support large ceiling panels in both length and width.

The clip-in system has a weight limitation and is restricted to panel sizes with a surface area of 1.0 m² or less. This system is easily accessible.

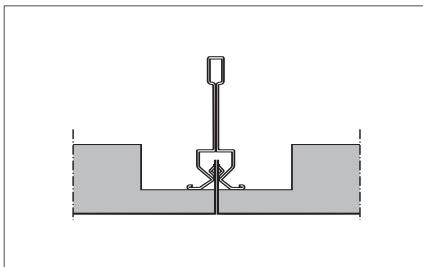

Clip-in system MA

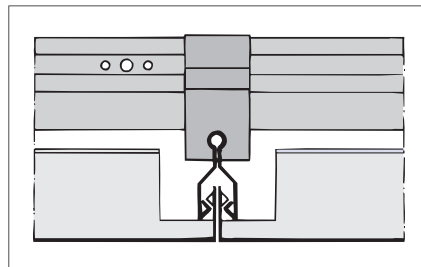

Clip-in system CC

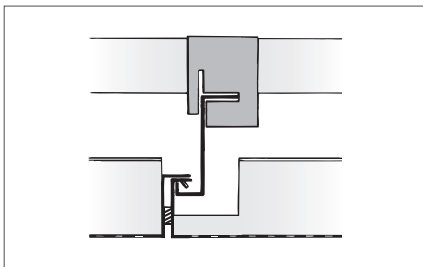

Hook-on system MG

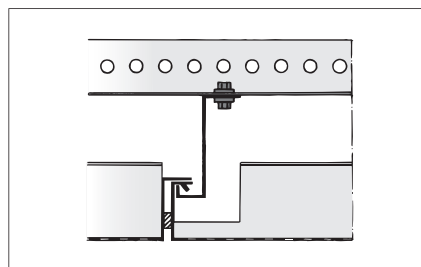

Hook-on system CZ

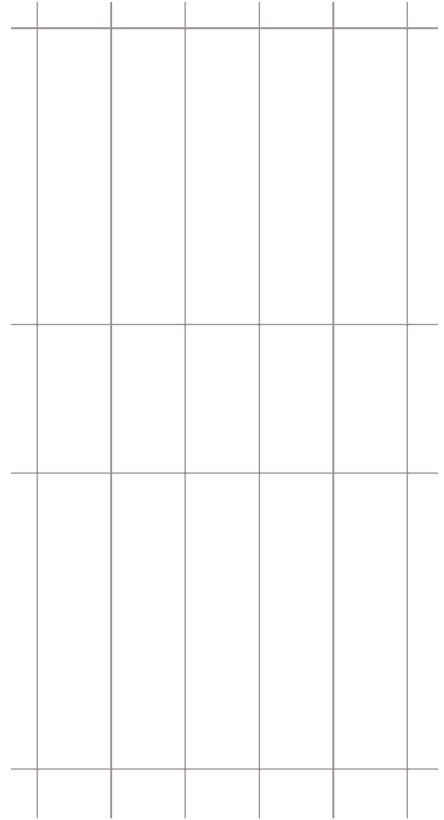

Clip-in and hook-on ceilings are also suitable for use in restricted void areas and with visible perimeter profiles when used as a ceiling island.



Removal of individual clip-in panels requires the use of a simple thin blade access tool which slides up into the joint and locks onto the top of the panel allowing it to be lowered and removed. Opening one or more individual swing panels provides simple and easy access to the plenum. They open from one side and hang vertically, supported by the two wings on the other side that remain firmly in the suspension grid.

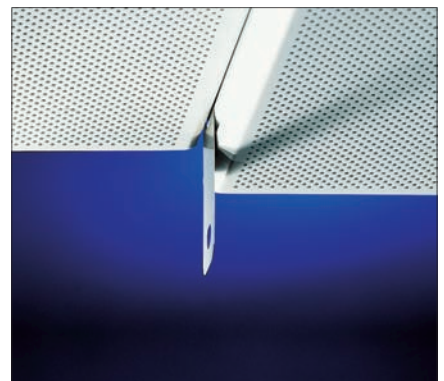

Clip-in system MA

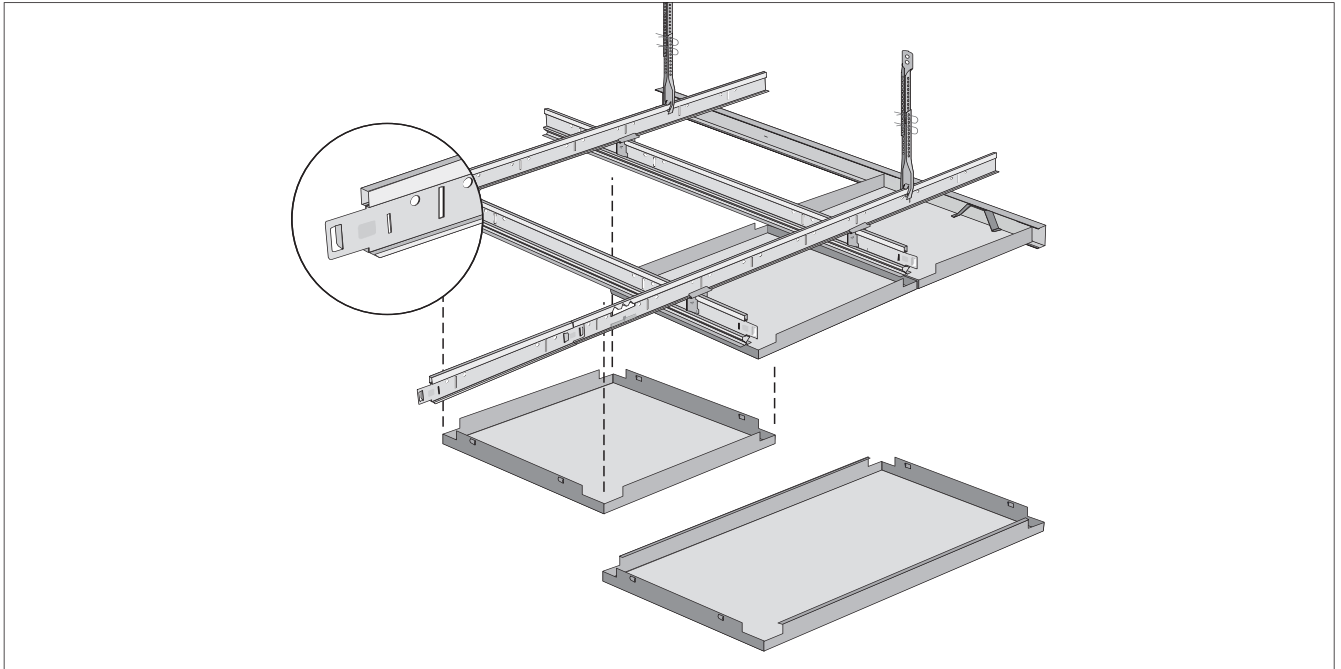

Clip-in suspension system MA

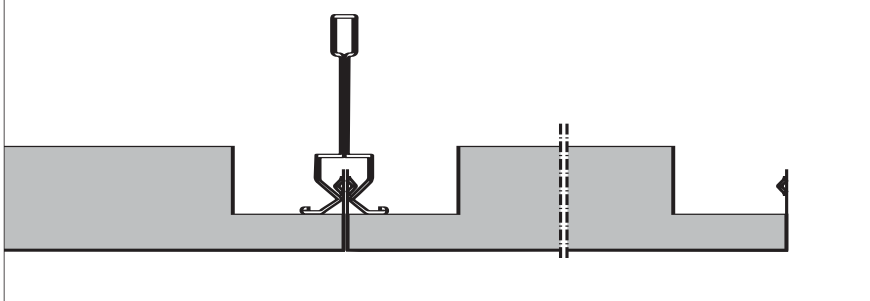

Upper and lower part nonius hangers

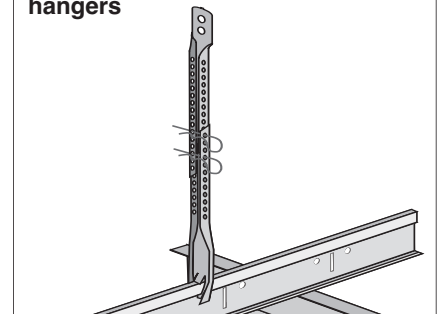

Primary profile - splice

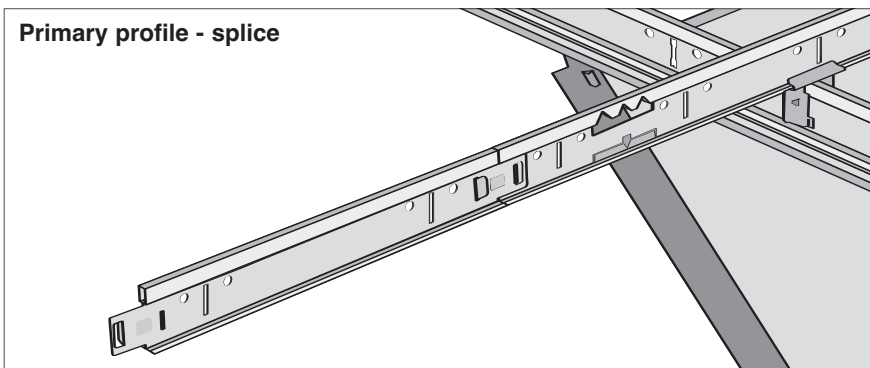

Cross connector

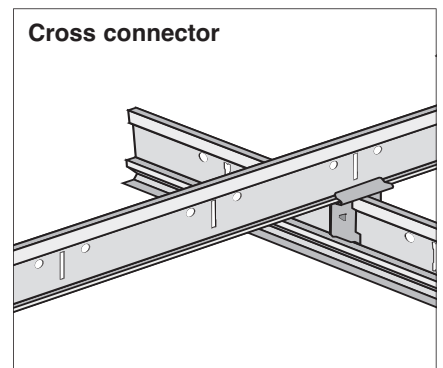

Details and components Clip-in system MA

Removal of individual clip-in panels requires the use of a simple thin blade access tool which slides up into the joint and locks onto the top of the panel allowing it to be lowered and removed.

Maximum panel dimensions and weights must not be exceeded. The suspension system consists of secondary clip-in profiles and primary profiles; together they guarantee a sturdy construction. Rigid nonius hangers (upper and lower part) best support the clip-in ceiling system.

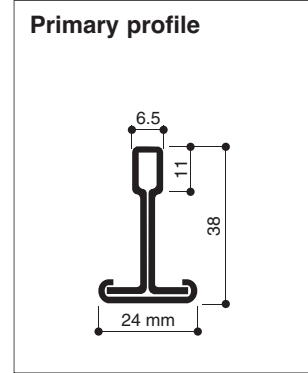
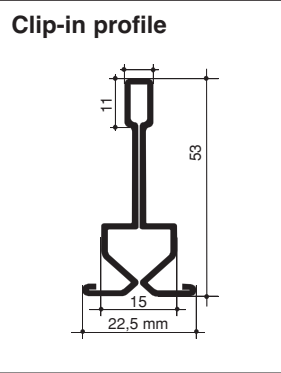

Clip-in profile

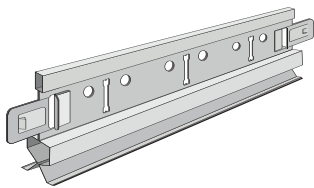

Product Number	Dimensions			Per carton			Per pallet		
	Length mm/ft	Thick. mm/"	kg./pc. lbs/pc.	pcs.	m/ft	kg/lbs	m ³	cartons	m ³
Steel with hemmed edges									
MA010D500H	3600	0.5	1.970	15	54.00	30.89	0.053	35	2.55
MA010E500H	3750	0.5	2.052	15	56.25	32.12	0.053	35	2.55
MA010.500H	12'	.020"	4.411	15	180'	69.14	0.053	35	2.55

Primary profile

450

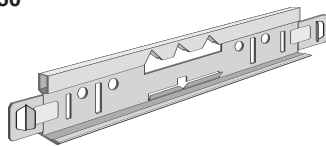

Product Number	Dimensions			Per carton			Per pallet		
	Length mm/ft	Thick. mm/"	kg./stuk lbs/Stck	stuks	m/ft	kg/lbs	m ³	cartons	m ³
Steel with steel capping									
-- 450 30 00	3600	0.4	1.280	25	90.00	33.26	0.039	50	2.41
-- 450 31 00	3750	0.4	1.333	25	93.75	34.56	0.039	50	2.41
-- 450 -- 00	12'	.015"	1.300	25	300'	33.74	0.039	50	2.41

Cross connector

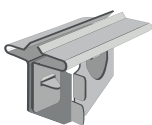

Product Number	Per carton		
	stuks	kg	m ³
MA021X500H	200	3.96	0.007

2 pieces per set. 1 carton = 100 sets cross connectors

Access tool



Product	Per carton
AT925X5005	100

Intersection clip

10228 200 pcs./carton



2 pieces per nonius hanger

Upper and lower part nonius hangers

Product	Product description
10230	Lower part H = 190 mm

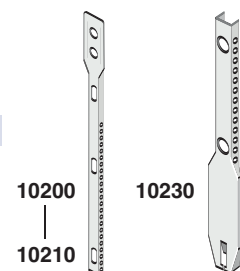

Clip-in system CC

The distance between hangers and carrier centres to comply with DIN 18168.

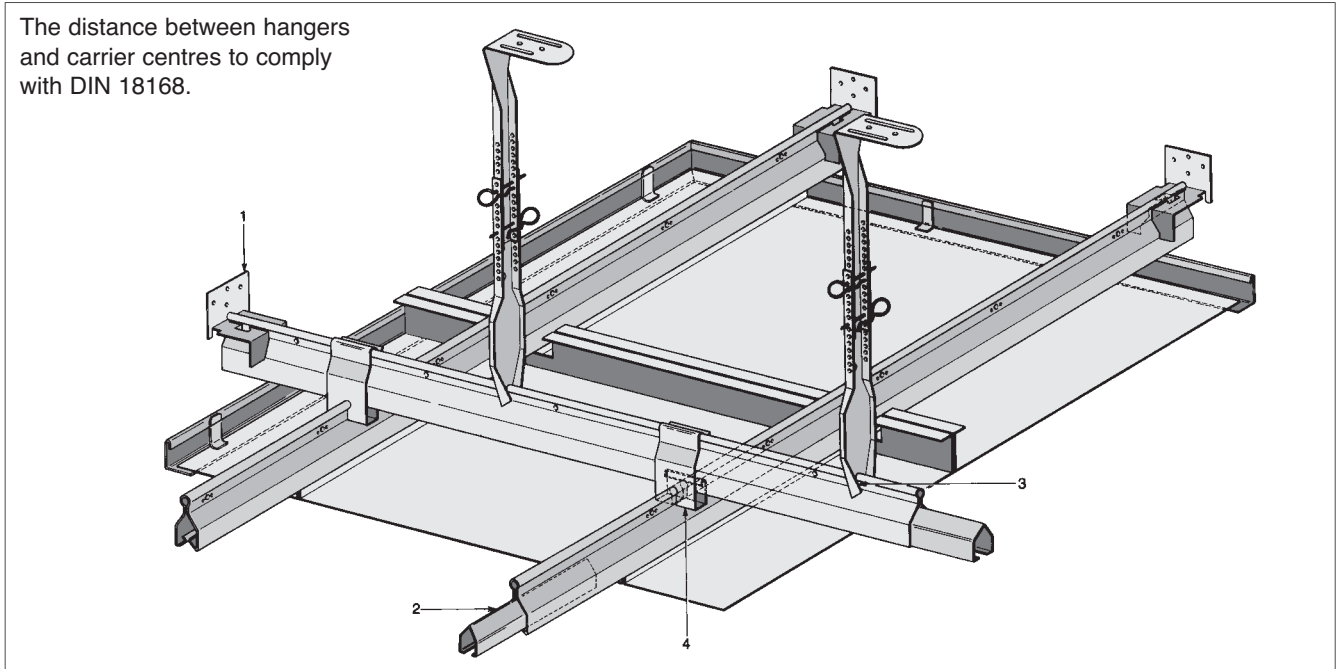

Clip-in profile – wall connection bracket

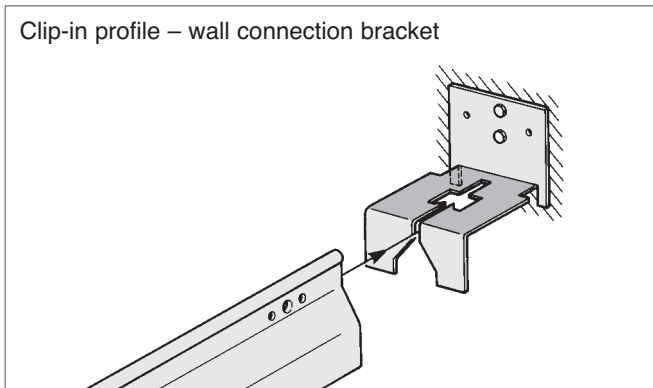

Clip-in profile – splice

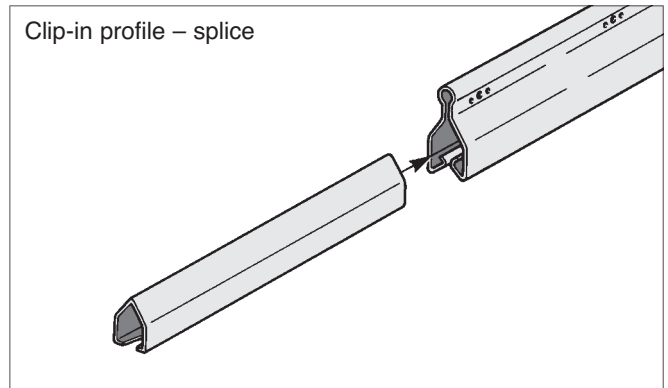

Clip-in profile – cross connector

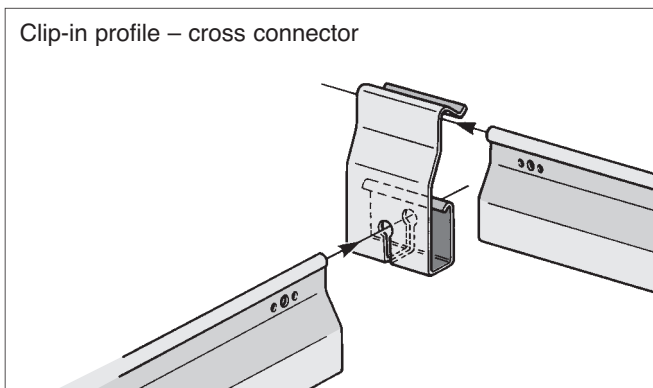

Nonius hanger (lower part)

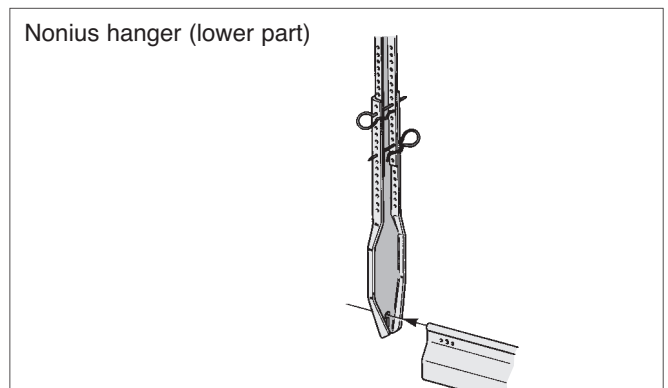

Details and components Clip-in system CC

The clip-in system CC can also be installed as a clip-in access or swing system. A simple access tool is used to open the ceiling. Maximum panel dimensions and weights must not be exceeded. The suspension system consists of secondary clip-in profiles and primary cross carriers; together they guarantee a sturdy construction. Rigid nonius hangers (upper and lower part) best support the clip-in ceiling system. The distance between hangers and carrier centres to comply with DIN 18168.

Clip-in profile

Material: galvanized steel
L = 4000 mm

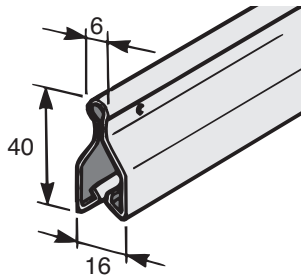

Clip-in profile – splice

Material: galvanized steel

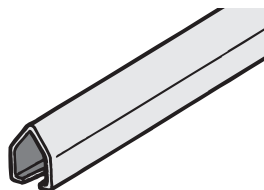

Clip-in profile – cross connector

Material: galvanized steel



Clip-in profile – wall connection bracket

Material: galvanized steel

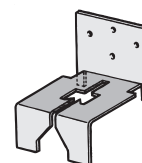

Nonius hanger lower part

Material: galvanized steel



Clip-in profile

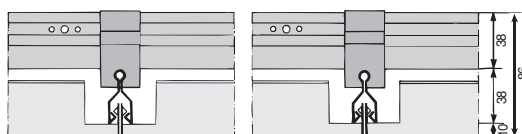

Primary suspension

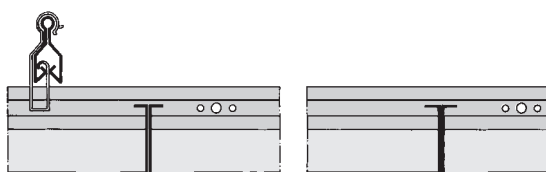

Clip-in Swing system

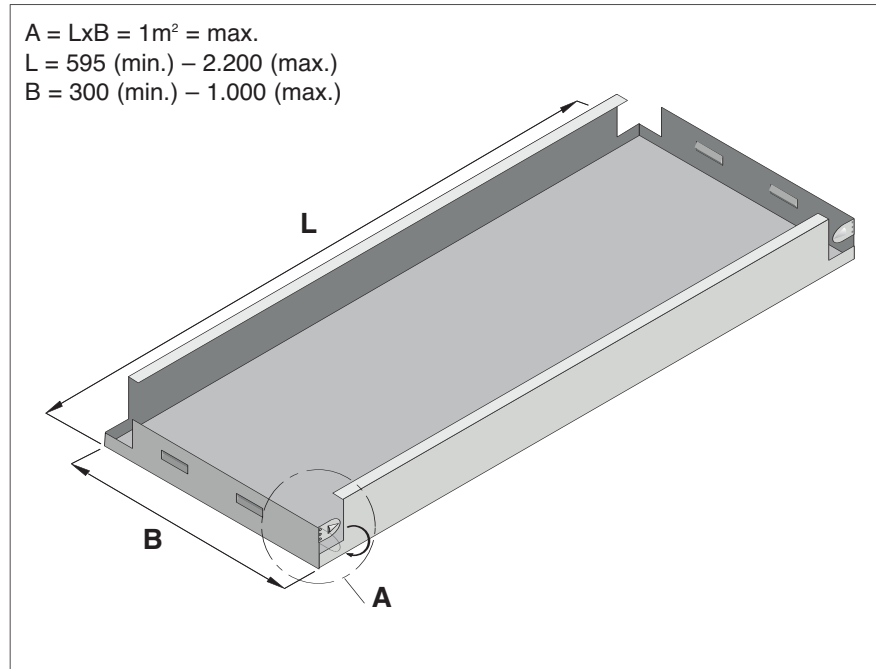

Characteristics and advantages:

- Access panels where desired.
- Bandrastrer ceiling possible.
- The best solution for the installation of chilled ceilings.
- Available perforated with acoustical fleece or plain.

Description:

- material thickness: 0,7 mm galvanized steel.
- panel width: from 300 to 1000 mm.
- panel length: from 595 to 2200 mm.
- panel surface area must not exceed 1 m².
- max. weight for lay-in: 7,0 kg/panel to maintain a safety factor of 3 to 1.

Finishing

- Polyester powder coated in colours 9010, 001 or 9006.
- Other colours available upon request

Installation

- Both wings must be bent outwards and parallel with the side of the panel. The swing access panel is located into the suspension system by pushing the wings into the clip-in profiles.
- The number of suspension points must comply with load bearing.

Accessibility

- All panels are easily accessible by means of an access tool or by simply pushing a hanger hook through the hole. To obtain a larger open work-space in the ceiling, the hanging panels can be glided to one side.

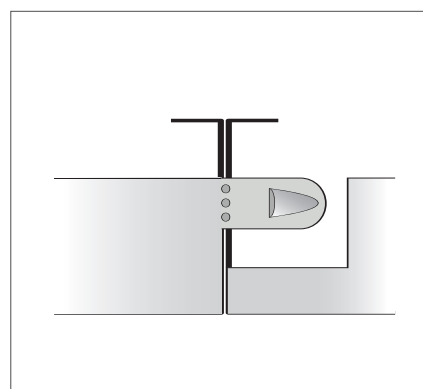
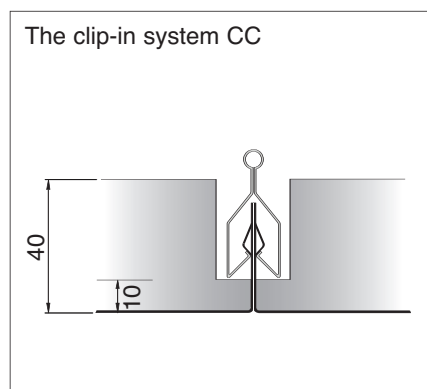
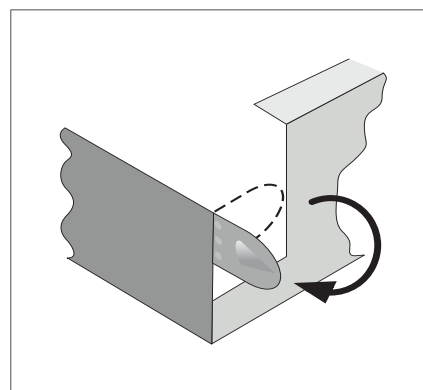
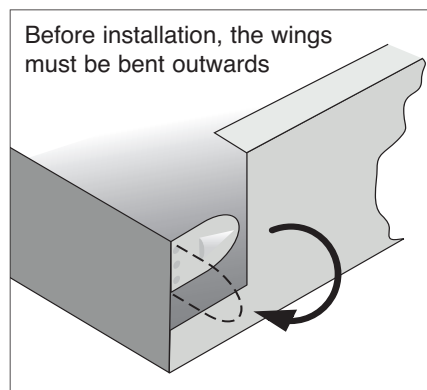

Rectangular panel ceiling construction.

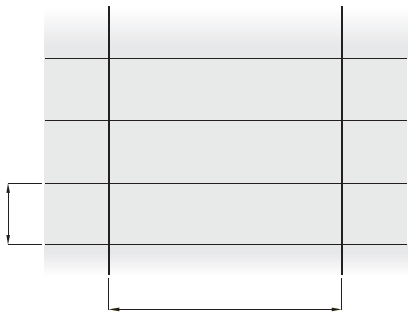

Square tile ceiling construction.

